

(UNIT : mm)

| SIZE | DIMENSION | | | | | | | | | | | DJPA-DR |
|--------|-----------|-----|-----|-----|---|----|-----|-----|--------------|-------|-----|---------|
| | d | g | c | D | f | t | L | A | MxN | H1 | H2 | |
| 1-1/2" | 40 | 81 | 105 | 140 | 2 | 16 | 165 | 160 | 4x ϕ 19 | 134 | 210 | KT-05 |
| 2" | 50 | 96 | 120 | 155 | 2 | 16 | 178 | 196 | 4x ϕ 19 | 141.5 | 222 | KT-10 |
| 2-1/2" | 65 | 116 | 140 | 175 | 2 | 18 | 190 | 196 | 4x ϕ 19 | 151 | 234 | KT-10 |
| 3" | 80 | 126 | 150 | 185 | 2 | 18 | 203 | 256 | 8x ϕ 19 | 190.3 | 252 | KT-20 |
| 4" | 100 | 151 | 175 | 210 | 2 | 18 | 229 | 256 | 8x ϕ 19 | 205.8 | 265 | KT-40 |
| 5" | 125 | 182 | 210 | 250 | 2 | 20 | 356 | 256 | 8x ϕ 23 | 230 | 285 | KT-60 |
| 6" | 150 | 212 | 240 | 280 | 2 | 22 | 394 | 280 | 8x ϕ 23 | 245 | 302 | KT-100 |

FOR APPROVAL

| * ACTUATOR SPECIFICATION | |
|-------------------------------|------------------------|
| ELECTRICAL | AC 110V,220V,380,DC24V |
| ROTATING ANGLE | 90° (-3° ~ +_ 95°) |
| OPERATING TYPE | ON/OFF,MODULATING |
| SERVICE TEMPERATURE | -20°C ~ +80°C |
| OPERATING TIME (CLOSE → OPEN) | 15~50SEC |
| MANUAL OVERRIDE | YES |

| REV. NO | DATE | REVISION RECORD | DRA. | CHK. | APR. |
|---------|------|-----------------|------|------|------|
| △ | | | | | |
| △ | | | | | |

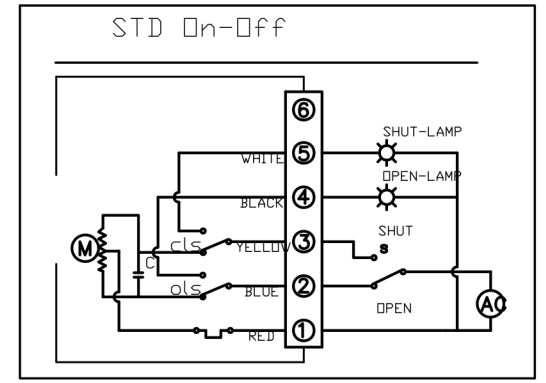

| NO. | DESCRIPTION | MATERIAL | Q'TY | REMARKS |
|-----|------------------------|----------|------|------------|
| 11 | - | - | - | |
| 10 | ACTUATOR | - | 1 | |
| 9 | BRACKET | - | 1 | |
| 8 | GASKET-BODY TO CLOSURE | P.T.F.E. | 1 | P.T.F.E. |
| 7 | THRUST WASHER | P.T.F.E. | 1 | CARBON 25% |
| 6 | V-PACKING | P.T.F.E. | 1SET | P.T.F.E. |
| 5 | STEM | A276 304 | 1 | |
| 4 | SEAT | R.T.F.E. | 2 | |
| 3 | BALL | SCS13/14 | 1 | |
| 2 | CAP | SCS13/14 | 1 | |
| 1 | BODY | SCS13/14 | 1 | |

PROJECT NAME
-

MEGATEC

| SCALE | ELECTRIC ON-OFF BALL V/V (JIS 10kg RF FLANGED/R.T.F.E. SEAT) | | |
|-----------------------------|---|------------------------------|----------------|
| DRAWN BY N.S. T.K.KIM | DATE 2017. 02. 16. | DRAWING NO. MOV17-0216-01 | REV. NO 1 A |
| APPROVED BY T.K.KIM | | | |